



TRUE EUROPE

Field's End Road, Goldthorpe, Nr. Rotherham, South Yorkshire S63 9EU, UK
 www.truemfg.com • Tel +44 01709 888 080 • Fax +44 01709 880 838
 Free Phone 0 800 783 2049 • Free Phone to U.S. 0 800 894 928



8/17

Model:
T-15G-HC-LD

T-Series:

Reach-In Glass Swing Door Refrigerator with Hydrocarbon Refrigerant & LED Lighting



T-15G-HC-LD

- ▶ Designed using the highest quality materials and components to provide the user with colder product temperatures, lower utility costs, exceptional food safety and the best value in today's food service marketplace.
- ▶ Designed using the highest quality materials and components to provide the user with colder product temperatures, lower utility costs, exceptional food safety and the best value in today's food service marketplace.
- ▶ Factory engineered, self-contained, capillary tube system using environmentally friendly R290 hydrocarbon refrigerant that has zero (0) ozone depletion potential (ODP), & three (3) global warming potential (GWP).
- ▶ High capacity, factory balanced refrigeration system that maintains cabinet temperatures of 33°F to 38°F (.5°C to 3.3°C) for the best in food preservation.
- ▶ Exterior - stainless steel front grill, ends, back and top.
- ▶ LED interior lighting provides more even lighting throughout the cabinet. Safety shielded.
- ▶ Energy efficient, "Low-E", double pane thermal insulated glass door.
- ▶ Adjustable, heavy duty PVC coated wire shelves.
- ▶ Positive seal self-closing door. Lifetime guaranteed door hinges.

Bottom mounted units feature:

- ▶ "No stoop" lower shelf.
- ▶ Storage on top of cabinet.
- ▶ Compressor performs in coolest, most grease free area of kitchen.
- ▶ Easily accessible condenser coil for cleaning.

PLAN VIEW

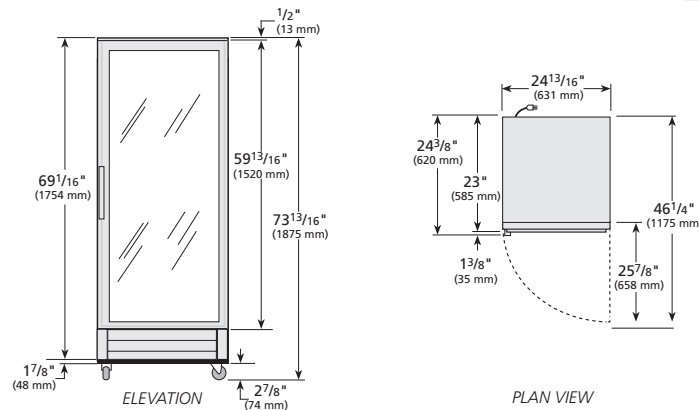

ROUGH-IN DATA

Specifications subject to change without notice.
 Chart dimensions rounded up to the next whole millimeter (inches rounded up to the next 1/8").

Model	Doors	Shelves	Cabinet Dimensions (mm)			HP	Voltage	Amps	Capacity (litres)	Refrigerant	Crated Weight (kg)
			W	D†	H						
T-15G-HC-LD	1	5	632	585	1877	1/5	230-240/50/1	1.4	377	R290	116

† Depth does not include 35 mm for glass door handle.